

**Thermocontroller built-in
Heater Controller
HCA series**



Heat-tech

1. Thermocontroller built-in heater controller HCA series

[Attention] HCA series can not control the halogen heater.

The control of the halogen heater recommends HCV series, HHC2 series, and SSC series.

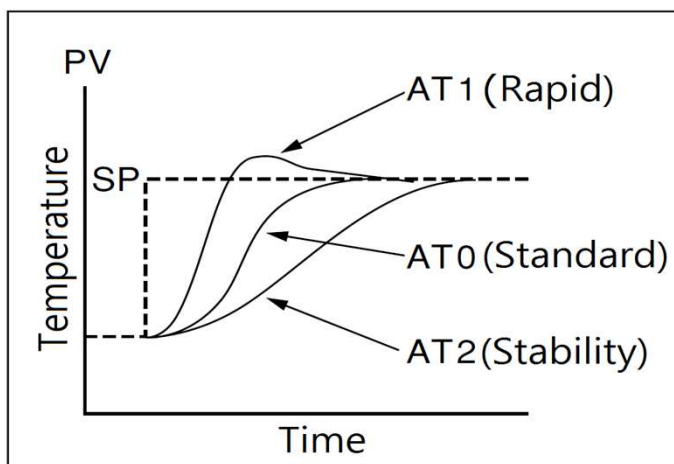

HCA has a built-in high-performance thermocontroller, handling is easy.

By overheating zero setting, providing a stable heating.

[Specifications]

D/#	Voltage	Current	Control	Supervisor function
HCA-AC100~240V-15A	AC100~240V	15A	1pcs	None
HCA-AC100~240V-30A	AC100~240V	30A	1pcs	None
HCAR-AC(In)V/(Out)V-15A	AC100~240V	30A	1pcs	None
HCASV-AC100~240V-15A	AC100~240V	15A	1pcs	Built-in
HCASV-AC100~240V-30A	AC100~240V	30A	1pcs	Built-in
HCAW-AC100~240V-15A	AC100~240V	15A	2pcs	None
HCAW-AC100~240V-30A	AC100~240V	30A	2pcs	None
HCAF-AC100~240V-15A	AC100~240V	15A	1pcs	None
HCAF-AC100~240V-30A	AC100~240V	30A	1pcs	None
HCAFMSV-AC100~240V-15A	AC100~240V	15A	1pcs	Built-in
HCAFMSV-AC100~240V-30A	AC100~240V	30A	1pcs	Built-in

Please contact us. about 50A ,100A and 150A products.

Option

D/#	Item and Description
BO	Heater burnout detection
RS-485	RS-485 Communication for IOT
PS	Non-airflow Alarm and current cut-off.
FPR	Front Protection Rail
RPR	Rear Protection Rail
LH	Lifting Handle
Power C	Manufacture the specification of the power cable.



【 Front Protection Rail 】

1-1. Standard type HCA



HCA has a built-in high-performance thermocontroller, handling is easy.
By overheating zero setting, providing a stable heating.

[Example : Air Blow Heater control]

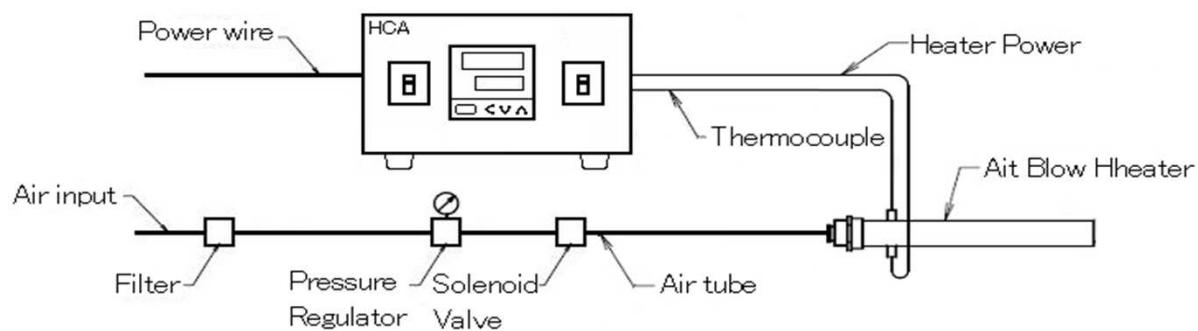

[Example : Far-infrared Line Heater control]

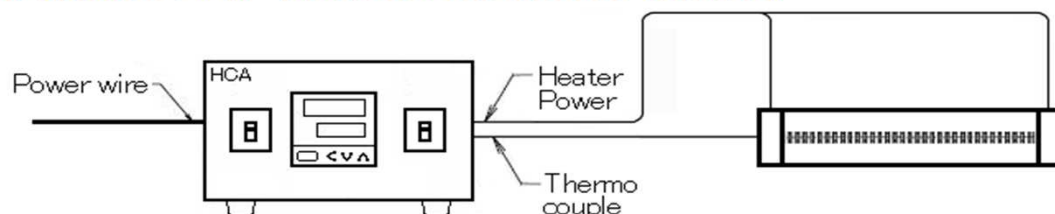

[Example : Panel Heater control]

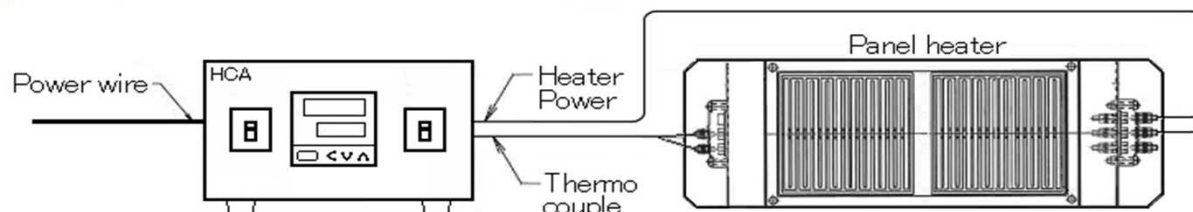

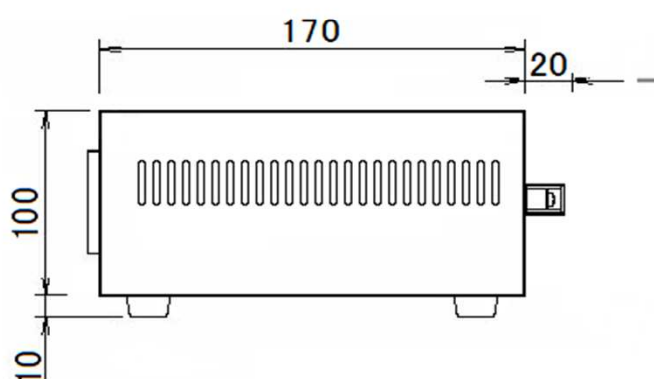
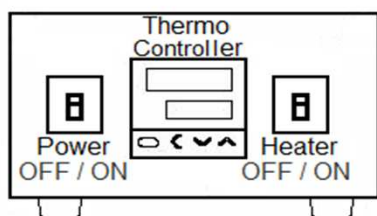
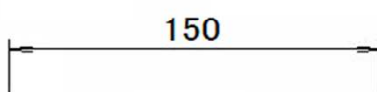
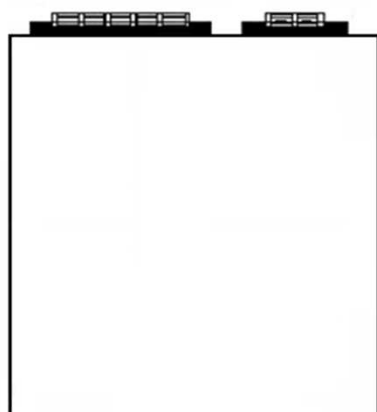

Control method	Time division PID control
Voltage	AC100V~220V
Current	15A / 30A
Option	B0 Heater Disconnection
Option	FPR Front Protection Rail
Option	RPR Raer Protection Rail
Dimention	Width 150 x height 110 x depth 205 mm
D/#	HCA-AC100V/220V-□A/ (Options)
Model	Thermocontroller built-in Heater Controller

Date	2016/5/3	Draw	Y.Shimoda
------	----------	------	-----------

Heat-tech Co.,Ltd.

1-2. Supervisor-function built-in HCASV



HCASV has a built-in high-performance thermocontroller, handling is easy.

By overheating zero setting, providing a stable heating.

1 heater is watched and controlled by 2 of thermocontroller.

[Example : Air Blow Heater Overheat Control]

In a hot-air outlet thermocouple input, it will control the hot air to the proper temperature. It will monitor the excessive rise in temperature of the Air Blow Heater in the heating element temperature thermocouple. When the excessive temperature rise occurs, it will send an alarm to cut off the heater power supply.

[Example : Air Blow Heater Target Heat Control]

The target thermocouple input, it will control the object at an appropriate temperature. It will monitor the excessive rise in temperature of the hot air heater in a hot air exit thermocouple. When the excessive temperature rise occurs, it will send an alarm to cut off the heater power supply.

[Example : Air Blow Heater Overheat Control]

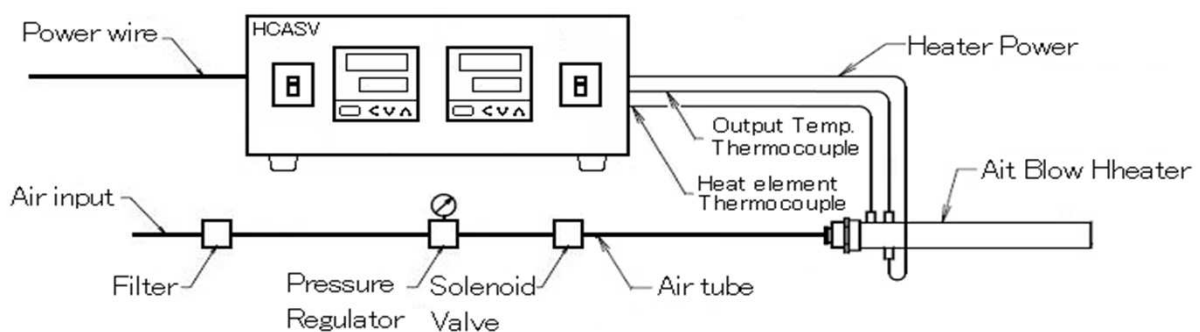

[Example : Air Blow Heater Target Heat Control]

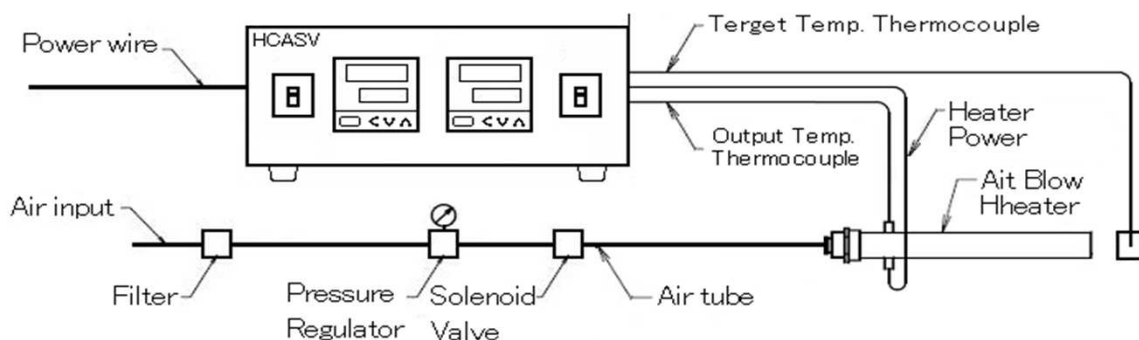

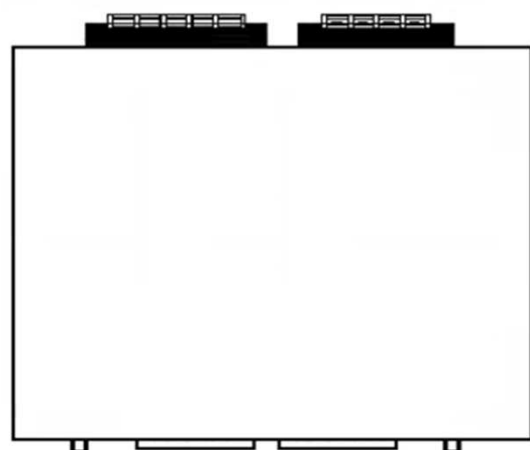

200

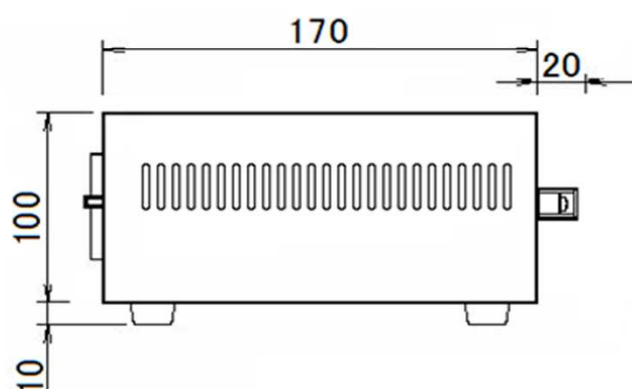
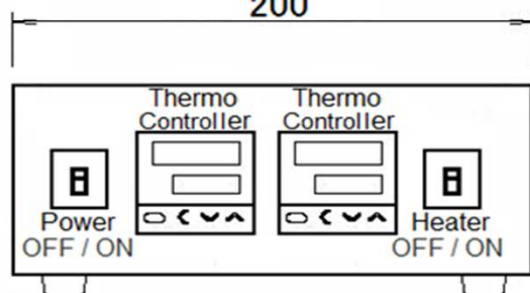

Control method	Time division PID control
Voltage	AC100V~220V
Current	15A / 30A
Option	BO Heater Disconnection
Option	FPR Front Protection Rail
Option	RPR Raer Protection Rail
Dimention	Width 200 x height 110 x depth 205 mm
D/#	HCASV-AC100V/220V-□A/(Options)
Model	Thermocontroller built-in Heater Controller

Date	2016/5/3	Draw	Y.Shimoda
------	----------	------	-----------

Heat-tech Co.,Ltd.



HCAW can control two heaters at the same time, such as the air blow heater, the far infrared rays line heater, and far infrared rays panel heater. Since the thermocontrollers are equipped with two, user can set the temperature individually. HCAW has a built-in high-performance thermocontroller, handling is easy. By overheating zero setting, providing a stable heating.

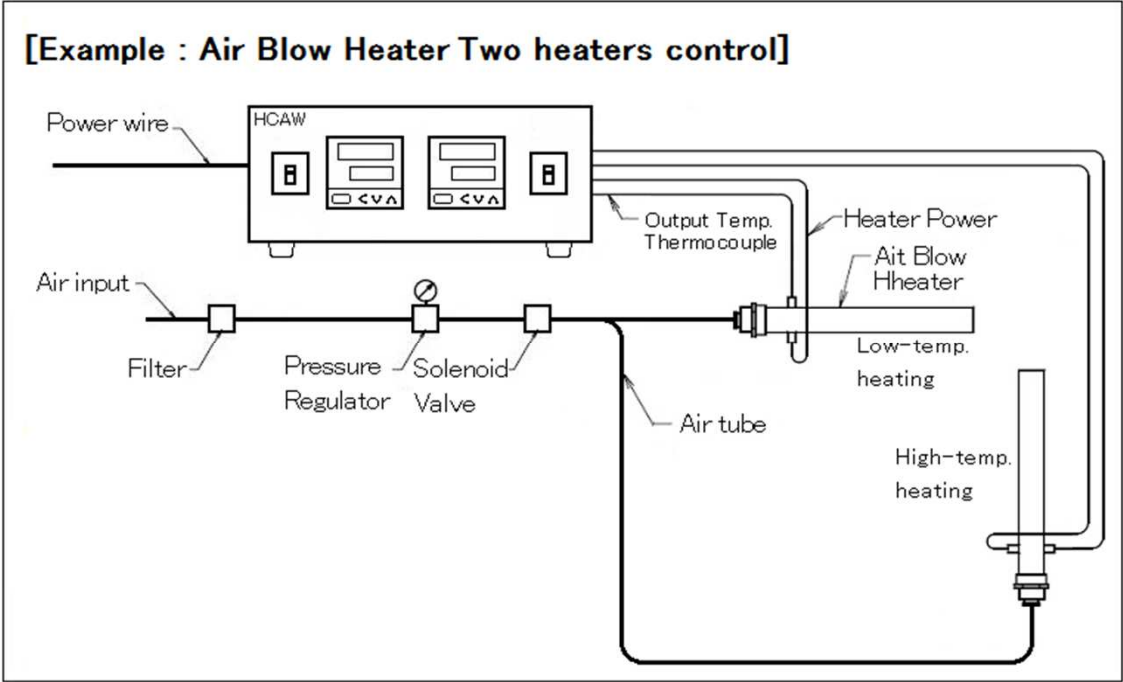

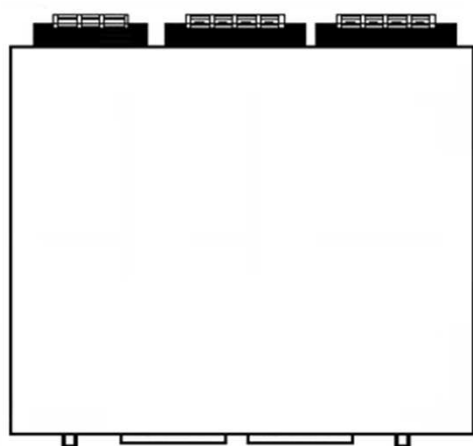

200

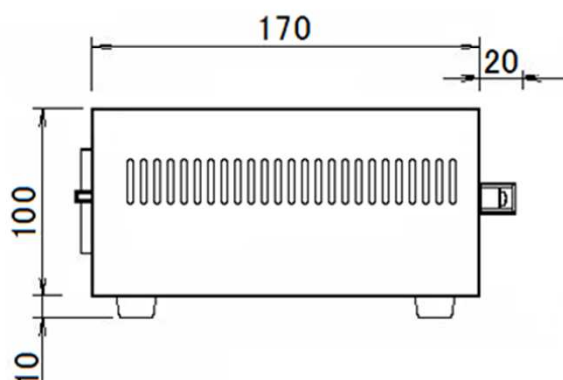
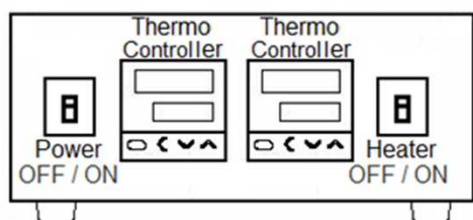

Control method	Time division PID control
Voltage	AC100V~220V
Current	15A / 30A
Option	BO Heater Disconnection
Option	FPR Front Protection Rail
Option	RPR Raer Protection Rail
Dimension	Width 200 x height 110 x depth 205 mm
D/#	HCAW-AC100V/220V-□A/ (Options)
Model	Thermocontroller built-in Heater Controller

Date 2016/5/3 Draw Y.Shimoda

Heat-tech Co.,Ltd.

1-4. Thermocontroller & Flow control type HCAFM



Temperature control and flow control of the Air Blow Heater can be performed.
By overheating zero setting, providing a stable heating.
The flow control valve can adjust the flow rate.
The built-in no-gas heating prevention function and prevents heat damage to the heater.
Since the main power switch and the heater power switch are separated, user can start the heating after the temperature setting.

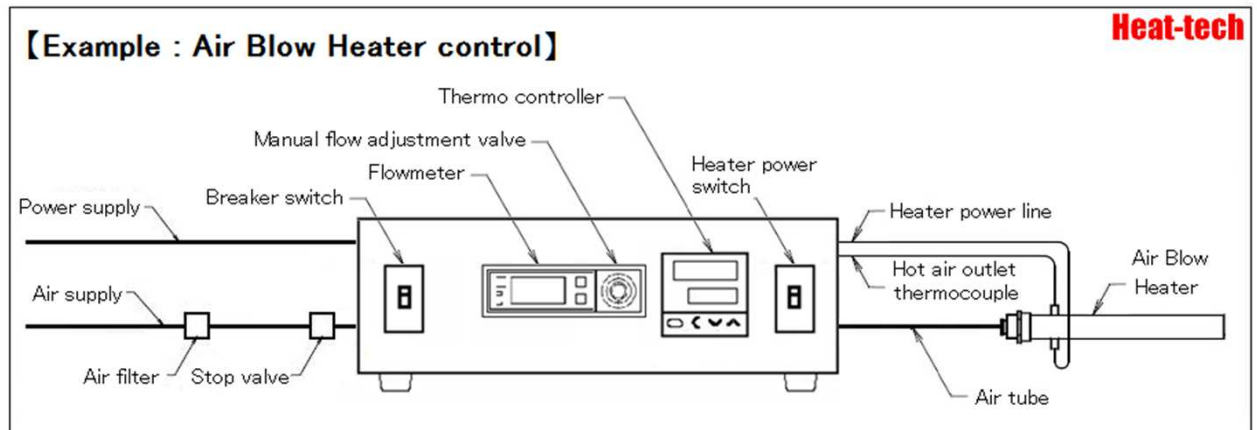

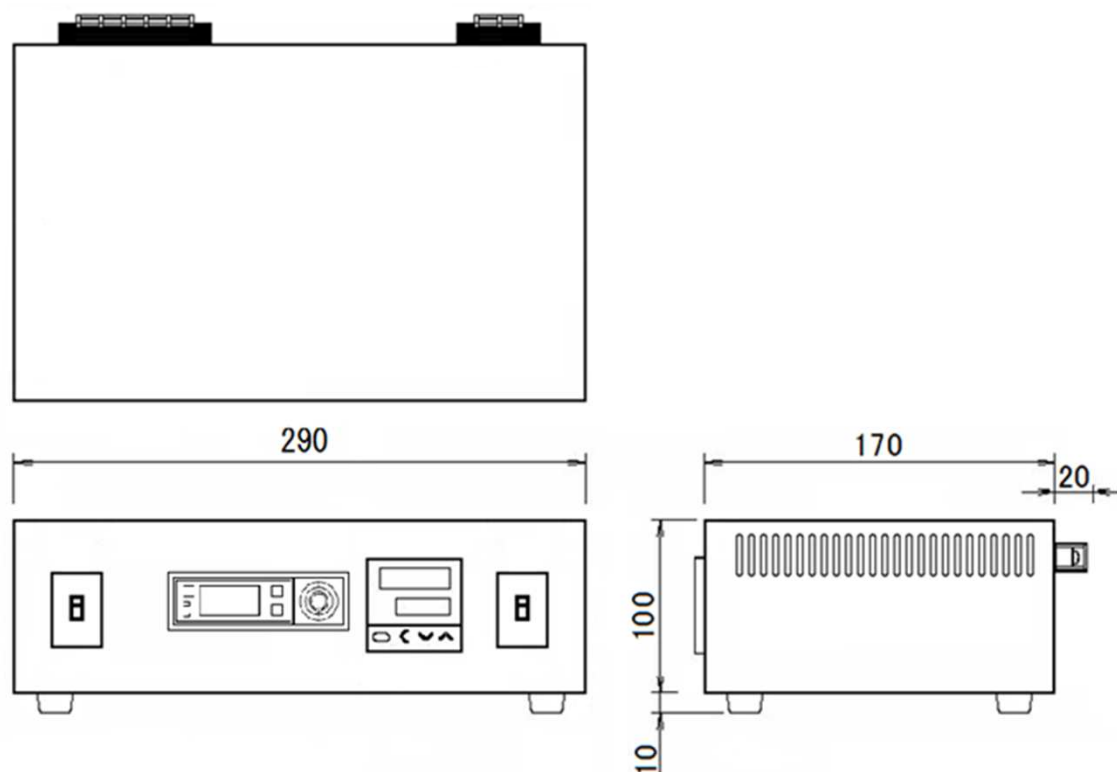

Option

BO	With heater burnout detection and display.
PS	Air Blow Heater and terminal cooling air pressure shortage alarm
RS-485	RS-485 Communication
AirV	Air opening and closing valve
SV	Supervisor function for Over-heat protect or Target-heating
HL	High-Low Control for rapid-heating or preheating
TMR	The setting timer one-shot heating and mounting surface.
R&H	Front Protection Rail, Rear Protection Rail and Lifting Handle

[Note] When the to add a function, there is that the external dimensions changes.

Control	Time division PID control
Voltage	AC100V~240V
Current	15A / 30A / 50A / 100A / 150A
Flow rate	0 ~ 200L/min
Dimension	Width 290 x height 110 x depth 205 mm
D/#	HCAFM-□A-200L/(Option)
Model	Thermocontroller built-in Heater Controller

Date 2019/4/5 Draw Y.Shimoda

Heat-tech Co.,Ltd.

2. Power Cable for Heater Controller

Manufacture the specification of the power cable.

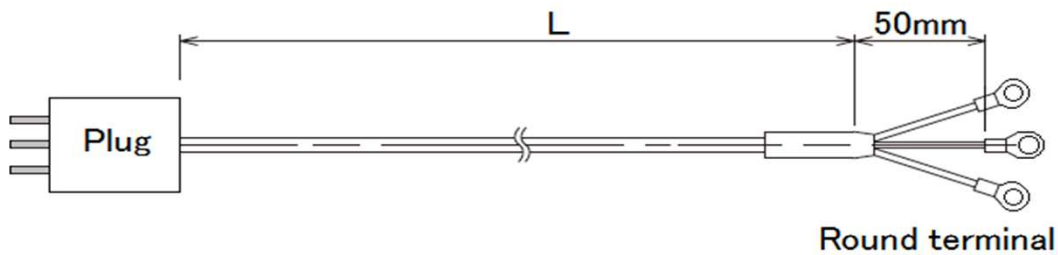

Round terminal

Type A	Type B	Type C	Type D	Type E	Type F
Type G	Type H	Type I	Type J	Type L	

VOLT	NEMA	15 AMPERE		20 AMPERE		30 AMPERE	
		Receptacle	Plug	Receptacle	Plug	Receptacle	Plug
125 V	L1						
		L1-15R	L1-15P				
250 V	L2						
				L2-20R	L2-20P		
125 V	L5						
		L5-15R	L5-15P	L5-20R	L5-20P	L5-30R	L5-30P
250 V	L6						
		L6-15R	L6-15P	L6-20R	L6-20P	L6-30R	L6-30P
277V, A.C.	L7						
		L7-15R	L7-15P	L7-20R	L7-20P	L7-30R	L7-30P
480 V	L8						
				L8-20R	L8-20P	L8-30R	L8-30P
600 V	L9						
				L9-20R	L9-20P	L9-30R	L9-30P

When the plug or the connector which the upper figure does not have are necessary, we will manufacture as much as possible.

<< Quotation model specification method >>

(Heater controller model) - (Plug shape) - (Cable length)

<< Quotation example >>

HCA-AC100/220V-15A-TypeA-5m

No-touch High Temperatures Hating

Heat-tech

Heat-tech Co., Ltd.

<https://heater.heat-tech.biz/>

International Medical Device Alliance IMDA

1-6-5 Minatojima Minamimachi Chuoku Kobe 650-0047 Japan

TEL 81-78945-7894 FAX 81-78945-7895

E-mail info@heat-tech.biz